

Product Accessories & Parts

We offer following Assembly Units/ Accessories including various parts/ components like following:

- Trippers
- Flap Gate
- Rod Gate
- R/P Gate
- Diverter Gate
- Bogie Balancer with driving & non driving wheel assy - All kinds
- Drive Pinion assy SCR
- Slew drive shaft SCR
- Buckets
- Apron Pans
- Telescopic chutes - All kinds
- Screw take up - All kinds
- Wheel Choker WT
- Wheel Gripper WT
- Pivot shaft assy WT
- Side Beam WT
- Clamp arm assy WT
- Guide wheel assy SAC
- Drive shaft assy - PF, BW, WT, SAC
- Blades -Paddle wheel
- PF drive wheel assy
- DE system



DELIVERING SOLUTIONS TO INDIA'S LEADING COMPANIES



POWER SECTOR



MINING, DEFENCE, SHIPPING, PAPER & PLYWOOD



STEEL & METALS



CONTRACTORS & INFRASTRUCTURE

INSPECTION AGENCIES



CONSULTANTS



CERTIFICATIONS



BTL EPC LIMITED

CIN No.: U29100WB1992PLC054541

Regd. Office - 2, Jessore Road, Dum Dum, Kolkata - 700 028

Corporate & Marketing Office

Shrachi Tower, 686 - Anandapur, EM Bypass,

RB Connector Junction, Kol - 700107 Ph: +91 98313 08714 / +91 90070 80314

E-mail: enquiry@shrachi.com Website: www.shrachi.com | btlepltd.com

Branch Office:

1 No. Gram Panchayat, Dag No.-999, Salap, Salap, Howrah, West Bengal, 711409

Social media presence

BTL EPC Ltd. SHRACHI AGRIMECH



For More Details



Bringing Agility to Engineering!

Catalogue For Products & Accessories





With the agility and work ethic of a thoroughbred racehorse, we at Shrachi BTL EPC Ltd. have been committed to the fluid expansion of India's infrastructure for the last 50 years. In this time, we have honed our expertise and worked on key projects, accumulating experience of providing instinctive, precise and winning turnkey solutions in an unmatched track record of maxing a nation's infrastructural ambitions.

ENTER THE WORLD OF BULK HANDLING DIVISION

Entered the Bulk Material Handling Equipment sector in the 1980s. Today, with more than 30 years of experience in this field, we now work for some of the most prestigious clients in the country. Our scope of work entails the design, manufacture, supply, erection and commissioning of Bulk Material Handling projects on a turnkey basis. Our operational sectors see us offer equipment and components for industrial systems in sectors like Steel, Power, Oil and gas, Cement, Mining, Coal and minerals, etc.

OUR KEY PRODUCTS

The following products feature prominently in our catalogue of offerings and are used to provide turnkey solutions to various companies in myriad sectors.



PIPE CONVEYOR



CONVEYOR IDLERS



GEAR BOX



SCREW CONVEYOR

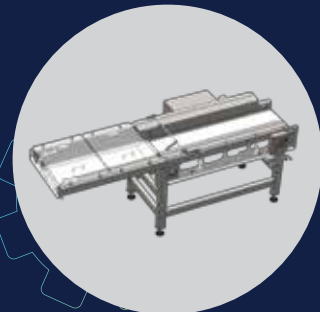

BELT CONVEYOR



FLAP GATE

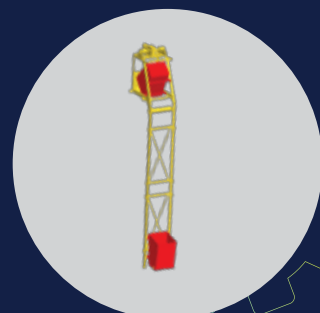

SKIP HOIST



PADDLE FEEDER



BUCKET ELEVATOR



PULLEYS



MECHANICAL VIBRATING & RECIPROCATING FEEDER



RACK & PINION GATE



INTERNAL SCRAPER

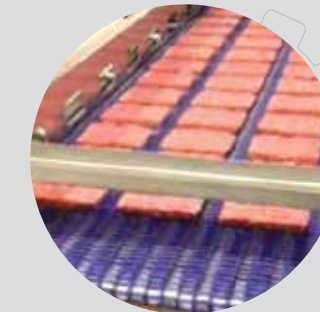

SHUTTLE CONVEYOR

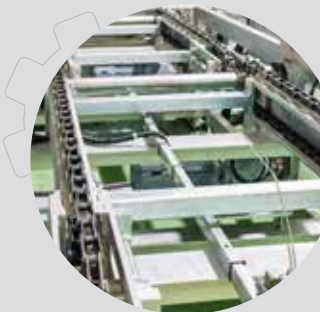

CHAIN CONVEYOR

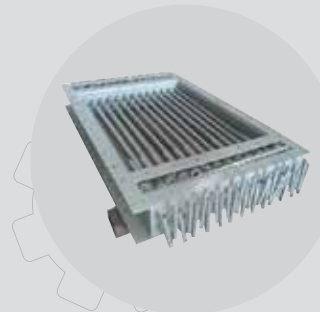

ROD GATE



BELT CONVEYOR



TRAVELLING TRIPPER



TRUCK & WAGON LOADER



TELESCOPIC CHUTE

